

DEMOUNTABLE AIR COMPRESSOR

FOR TRACTORS
Powered by Tractor's
Hydraulic Pump

Part No. EHC 001

A useful demountable air compressor unit designed to be powered by the hydraulic pump on an agricultural tractor. The unit consists of an air compressor, hydraulic motor and belt-drive assembly, all mounted on a powder-coated steel base. This sits on four rubber bobbins, ready to attach to suitable points on the back of your tractor. Two hoses connect the tractor's hydraulic pump to the motor which then drives the air compressor. The drive belt and pulleys are totally enclosed within a steel case, and this has a removable cover for access. A stainless steel braided high-pressure air hose is connected to the compressor outlet, and this is also supplied with the unit.

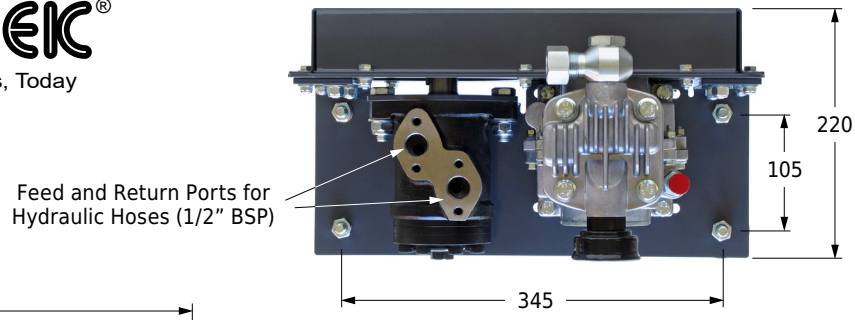

Dimensions in millimetres

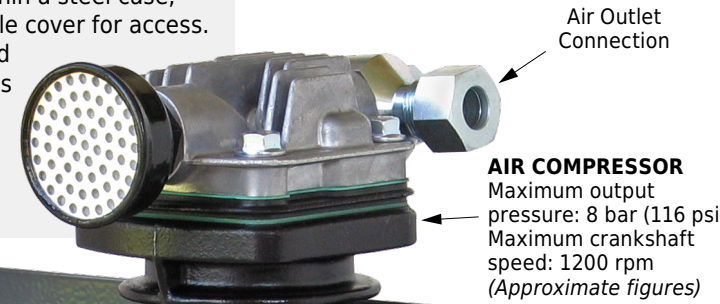
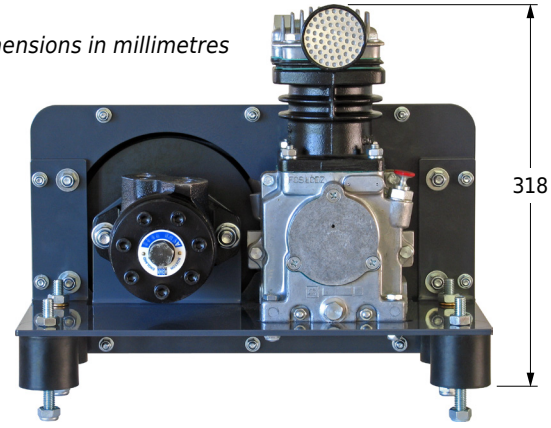
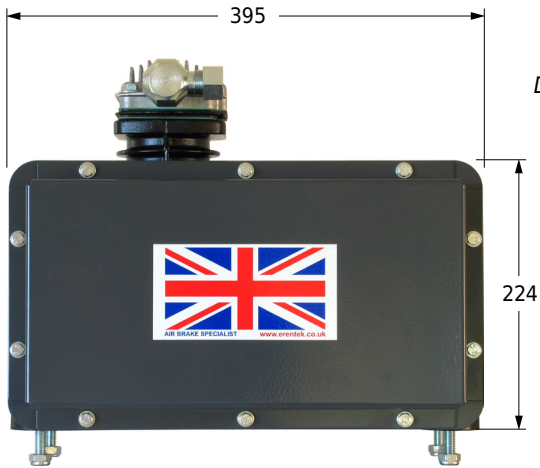

HYDRAULIC MOTOR
Rotation speed at 35 litres/min input and 50 bar (725 psi) fluid pressure: 810 rpm (Approximate figures)

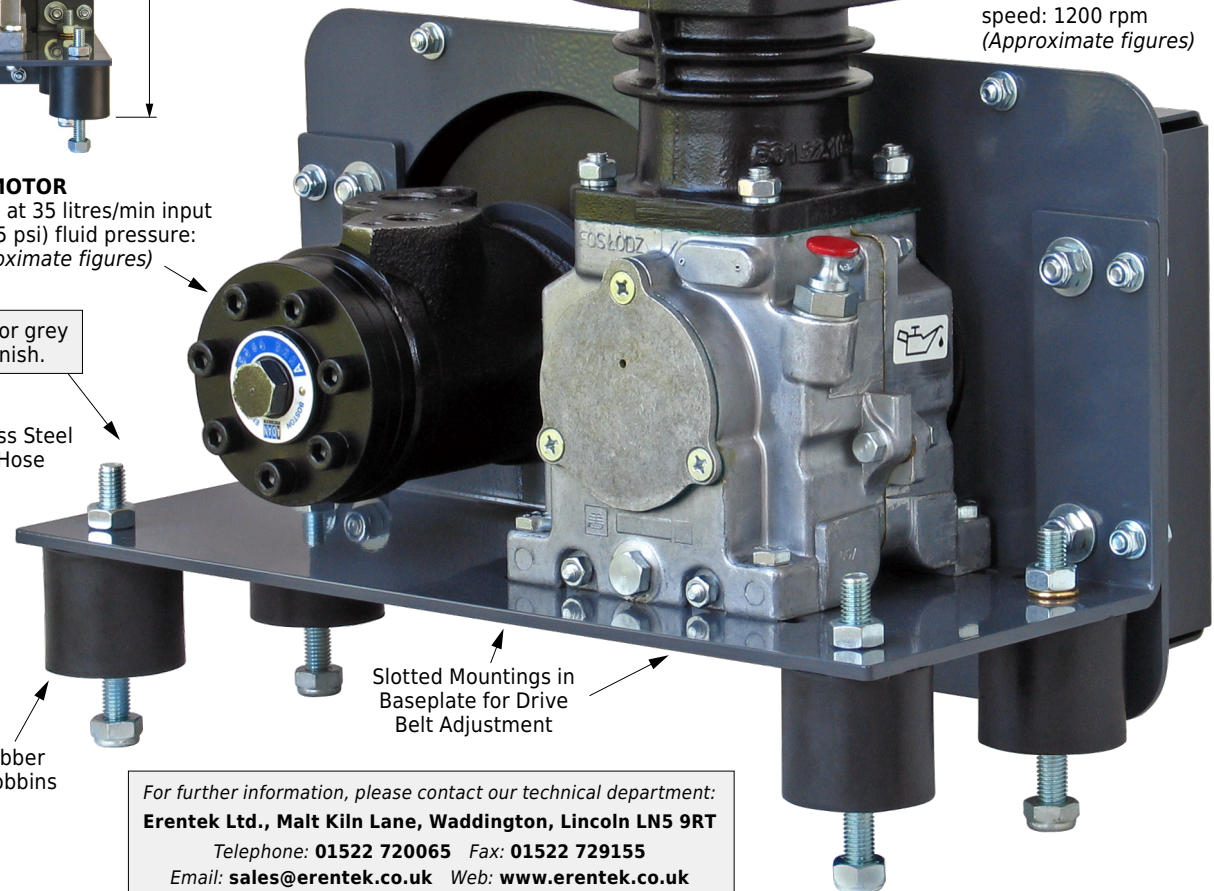
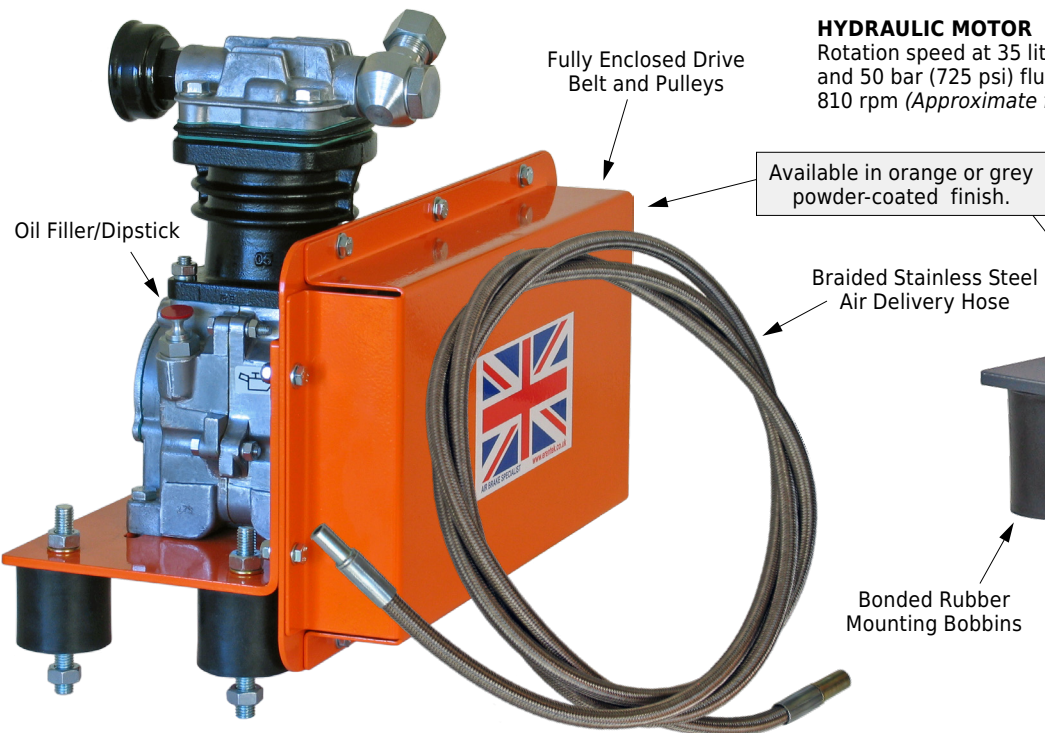

For further information, please contact our technical department:
Erentek Ltd., Malt Kiln Lane, Waddington, Lincoln LN5 9RT
Telephone: 01522 720065 Fax: 01522 729155
Email: sales@erentek.co.uk Web: www.erentek.co.uk